

# FSC-BW3583V

DATASHEET V1.1

## Copyright © 2013-2025 Shenzhen Feasycom Co., Ltd. All Rights Reserved.

Shenzhen Feasycom Co., Ltd reserves the right to make corrections, modifications, and other changes to its products, documentation, and services at any time. Customers are advised to obtain the latest relevant information before placing orders. In order to minimize product risks, customers should implement sufficient design and operational safeguards. Reproduction, transfer, distribution, or storage of any part or all of the contents in this document, in any form, without written permission from Shenzhen Feasycom Co., Ltd, is strictly prohibited.

### Revision History

Version	Date	Notes	Writer
1.0	2024/09/26	Initial Version	Qiu
1.1	2025/11/14	Add pictures of the product's bottom and optimize the content	Qiu

### Contact Us

Shenzhen Feasycom Co., Ltd

Email: [sales@feasycom.com](mailto:sales@feasycom.com)

Address: Rm 508, Building A, Fenghuang Zhigu, No.50, Tiezai Road, Xixiang, Baoan District, Shenzhen, 518102, China  
Tel: 86-755-27924639, 86-755-23062695

## 1. INTRODUCTION

### Overview

FSC-BW3583V is a highly integrated module that supports dual-band Wi-Fi 6 and BT 5.4 for wireless applications, with enhanced qualification based on selective AEC-Q100 and JEDEC test cases.

### Wi-Fi 6 Features

- CMOS single-chip fully-integrated RF, Modem and MAC
- Support 2.4G/5GHz Wi-Fi 6
- Data rates up to 600Mbps with 20/40/80MHz bandwidth
- Support 5MHz/10MHz mode
- RX sensitivity -92dBm in 11b 1M mode
- Tx power up to 21dBm in 11b mode, 18dBm in HT/VHT/HE MCS0 mode
- Support STA, AP, Wi-Fi Direct modes concurrently
- Support STBC, beamforming, and Wi-Fi 6 TWT
- Support WEP/WPA/WPA2/WPA3-SAE Personal, MFP

### BT 5.4 Features

- Supports all the mandatory and optional features of Bluetooth 2.1+EDR/3.0/4.x/5.3/5.4
- Supports advanced master and slave topologies

### Other Features

- Supports SDIO3.0/HCI\_UART interface
- Integrated low power timer and watchdog

### Applications

- IoT devices
- Wireless devices

**Module picture as below showing** (Laser Engraving of Dual Antennas)



## 2. GENERAL SPECIFICATIONS

Table 2-1: General Specifications

Categories	Features	Implementation		
Bluetooth				
	Bluetooth Standard	BT BR/LE/EDR V5.4		
	Frequency Band	2402MHz~2480MHz		
	Bluetooth class	Class 1		
	Transmit power	8 ± 2dBm		
	Receiver sensitivity	-92dBm @ enhance data rate		
		-92dBm @ basic rate		
		-92dBm @ low energy		
	Support mode	Slave and Master		
	Profiles	HFP, A2DP, AVRCP, SPP, PBAP, HID, DUN, FTP, GATT, ANCS		
	Maximum throughput	2Mbps		
	Interface	UART,		
Wi-Fi				
	Wi-Fi standard	2.4G: IEEE802.11 b/g/n/ax 5G: IEEE802.11 a/n/ac/ax		
	Frequency Band	2.4GHz and 5GHz		
	2.4G Output Power	802.11b /11Mbps : 18dBm ± 2 dB	EVM≤-9dB	
		802.11g /54Mbps : 17dBm ± 2 dB	EVM≤-25dB	
		802.11n /MCS0: 18dBm ± 2 dB	EVM≤-10dB	
		802.11n /MCS7: 16dBm ± 2 dB	EVM≤-28dB	
		802.11ax /MCS0: 16dBm ± 2 dB	EVM≤-15dB	
		802.11ax /MCS11: 14dBm ± 2 dB	EVM≤-35dB	
		5G Output Power	802.11a /54Mbps : 15dBm ± 2 dB	EVM≤-25dB
			802.11n /MCS0: 18dBm ± 2 dB	EVM≤-10dB
			802.11n /MCS7: 14dBm ± 2 dB	EVM≤-28dB
			802.11ac /MCS0: 18dBm ± 2 dB	EVM≤-15dB
	802.11ac /MCS11: 14dBm ± 2 dB		EVM≤-35dB	
	802.11ax /MCS0: 15dBm ± 2 dB		EVM≤-15dB	
	2.4G Rx Sensitivity	802.11ax /MCS11: 13dBm ± 2 dB	EVM≤-35dB	
		-90dBm @11b 1M		
		-84dBm @11b 11M		
		-88dBm @11g 6M		
		-72dBm @11g 54M		
		-89dBm @HT20 MCS0		
		-65dBm @HT40 MCS7		
	-88dBm @HE20 MCS0			
	-56dBm @HE20 MCS11			

		-84dBm @HE40 MCS0 -53dBm @HE40 MCS11
	5G Rx Sensitivity	-88dBm @6M bps OFDM -70dBm @54M bps OFDM -88dBm @HT20 MCS0 -67dBm @HT40 MCS7 -88dBm @HE20 MCS0 -87dBm @HE40 MCS0 -58dBm @HE40 MCS11 -82dBm @HE80 MCS0 -50dBm @HE80 MCS11
Security		WEP/WPA/WPA2/WPA3-SAE
Interface		SDIO/USB
Size		17mm(L) x 17mm(W) x 2.4mm(H)(with shielding cover) 17mm(L) x 17mm(W) x 2.1mm(H)(without shielding cover) 17mm(L) x 17mm(W) x 1.7mm(H)( without shielding cover and IPEX)
Antenna		External (Dual-band antenna, supporting 2.4GHz and 5.8GHz frequencies)
Operating temperature		-40°C ~ +85°C
Storage temperature		-40°C ~ +85°C
Operating voltage (VDD_3V3)		3.0 ~ 3.6V (Peak Current:1.5A)
VIO		1.8V or 3.3V
Miscellaneous	Lead Free Warranty	Lead-free and RoHS compliant One Year
Humidity		10% ~ 90% non-condensing
MSL grade:		MSL 3
ESD grade:		Human Body Model: Pass ±3000 V, all pins Charge device model: Pass ±800 V, all pins

### 3. HARDWARE SPECIFICATIONS

#### 3.1 Block Diagram and PIN Diagram

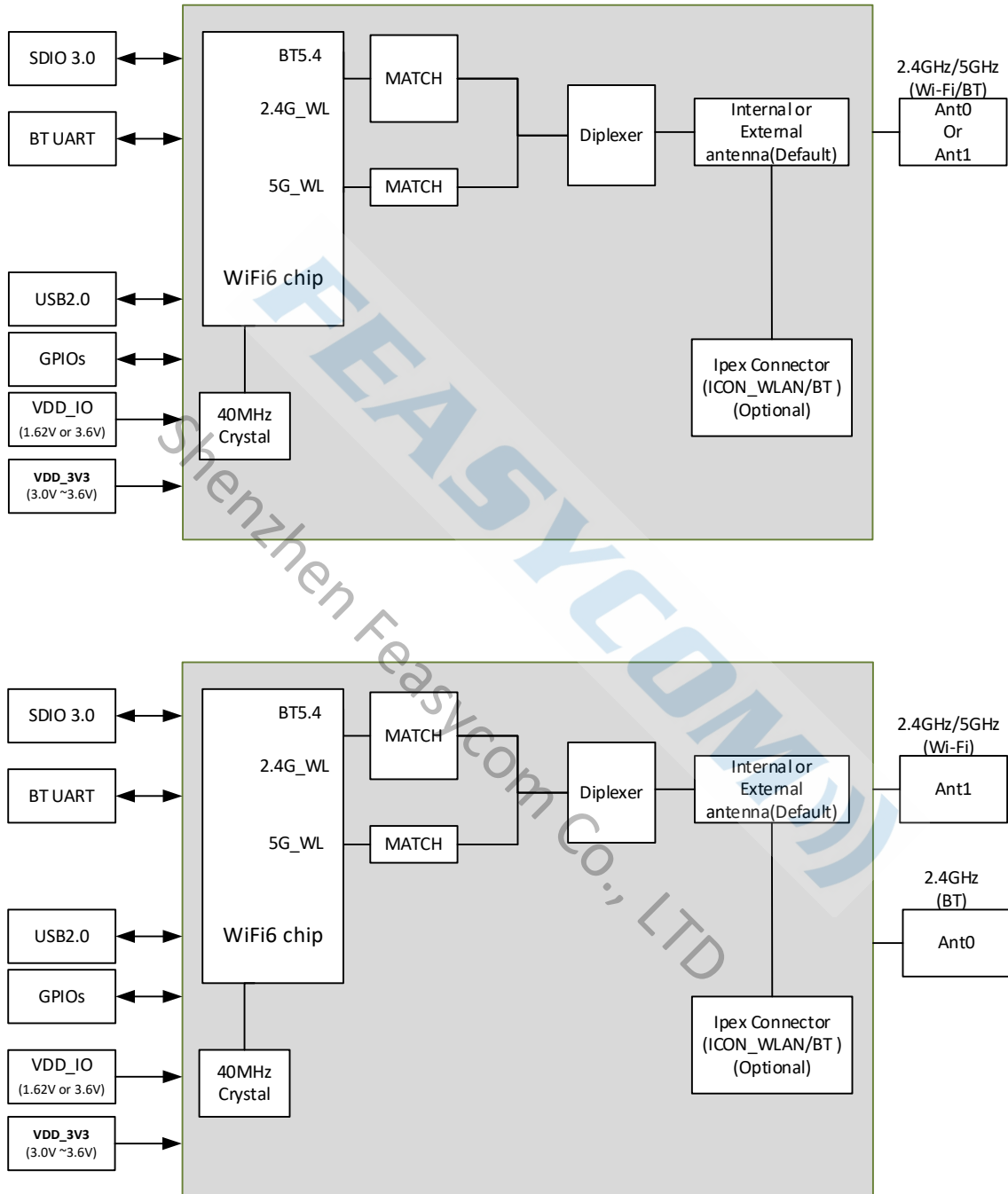

Figure3-1-1: FSC-BW3583V Block Diagram

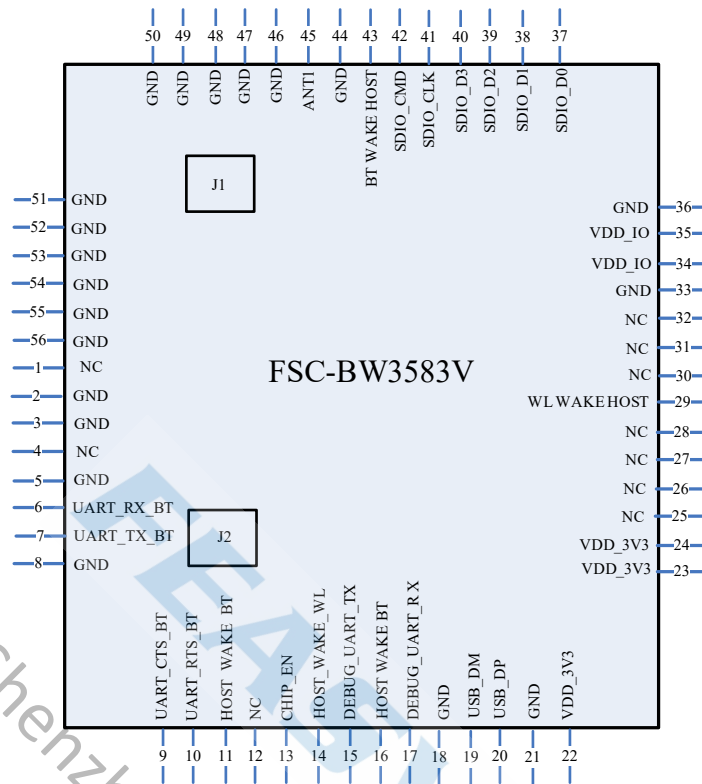

Figure3-1-2:FSC-BW3583V Pin Diagram(Top View)

### 3.2 PIN Definitions

Table 3-2: Pin definitions(This is the single-antenna version. Please contact us if you need other versions.)

Pin	Pin Name	Type	Pin Descriptions	Notes
1	NC	RF	Wi-Fi 6 2.4G/5G/BT antenna0 (optional)	
2	GND		Ground connections	
3	GND		Ground connections	
4	NC		NC	
5	GND		Ground connections	
6	UART_RX_BT	I	High speed UART Data In	
7	UART_TX_BT	O	High speed UART Data Out	
8	GND		Ground connections	
9	UART_CTS_BT	I	High speed UART CTS	
10	UART_RTS_BT	O	High speed UART RTS	
11	HOST WAKE BT		HOST wake-up Bluetooth device	
12	NC		NC	
13	CHIP_EN	I	Enable / Disable BT and WIFI	
14	HOST WAKE WL	I/O	HOST wake-up Wlan device	

15	DEBUG_UART_TX	O	Debug serial port Tx Hang in the air when not in use, no need to connect
16	HOST_WAKE_BT	I/O	HOST wake-up Bluetooth device (Connect to pin 14; either one is sufficient.)
17	DEBUG_UART_RX	I	Debug serial port Rx Hang in the air when not in use, no need to connect
18	GND		Ground connections
19	USB_DM	I/O	USB data D- Hang in the air when not in use, no need to connect
20	USB_DP	I/O	USB data D+ Hang in the air when not in use, no need to connect
21	GND		Ground connections
22	VDD_3V3	PWR	3.3V Supply Voltage
23	VDD_3V3	PWR	3.3V Supply Voltage
24	VDD_3V3	PWR	3.3V Supply Voltage
25	NC		NC
26	NC	O	NC (Leave the pin floating.)
27	NC	O	NC (Leave the pin floating.)
28	NC	I	NC (Leave the pin floating.)
29	WL_WAKE_HOST		Wlan device wake-up HOST
30	NC		NC
31	NC		NC (Leave the pin floating.)
32	NC		NC
33	GND		Ground connections
34	VDDIO	PWR	1.8V or 3.3V Supply Voltage
35	VDDIO	PWR	1.8V or 3.3V Supply Voltage
36	GND		Ground connections
37	SDIO_D0	I/O	SDIO Data Line0
38	SDIO_D1	I/O	SDIO Data Line1
39	SDIO_D2	I/O	SDIO Data Line2
40	SDIO_D3	I/O	SDIO Data Line3
41	SDIO_CLK	I	SDIO Clock Input
42	SDIO_CMD	I/O	SDIO Command Input
43	BT_WAKE_HOST	I/O	Bluetooth device wake-up HOST
44	GND		Ground connections
45	ANT1	RF	Wi-Fi 6 2.4G/5G/BT antenna1
46-56	GND		Ground connections
J1	NC	RF	Wi-Fi 6 2.4G/5G/BT IPEX ANT(optional)
J2	NC	RF	BT IPEX ANT(optional)

## 4. ELECTRICAL CHARACTERISTICS

### 4.1 DC Characteristics

Table 4-1: Power Supply Characteristics

Parameter	Min	Type	Max	Unit
Operating Temperature	-40	25	85	°C
VDD_3V3	3.0	3.3	3.6	V
VDD_IO	1.62	1.8 or 3.3	3.6	V

### 4.2 Power Supply DC Characteristics

Table 4-2: Power Consumption

Symbol	Parameter	Type	Unit
Power Consumption	2.4G TX HT40 11n MCS7@18dBm	145	mA
	5G TX HT40 11n MCS7@18dBm	160	mA
	RX Mode	60	mA
	BT 1M@13 dBm	60	
	BT RX Mode	60	mA

## 5. PHYSICAL INTERFACE

### 5.1 System Power on Sequence

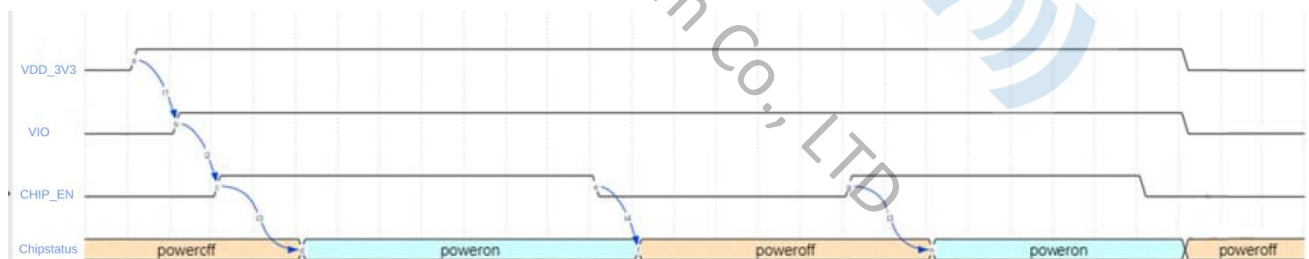

Figure 5-1: System Power on Sequence

t1: VIO's power on time  $\geq$  VDD\_3V3's

t2: CHIP\_EN's high time  $\geq$  VIO's +200us

t3: chip all power on ready time  $\geq$  CHIP\_EN high time + 8ms

t4:CHIP\_EN pull low to chip all power off time  $\geq$ 6ms

## 5.2 UART Interface

The four signal pins facilitate the UART function on the FSC-BW3583V. When connecting this module to another digital device, UART\_RX and UART\_TX facilitate data transmission between the two devices. Additionally, UART\_CTS and UART\_RTS support RS232 hardware flow control. Both pins operate effectively at a low level, enabling transmission when the signal is low and pausing transmission when the signal is high.

When connecting the module to a host, please make sure to follow.

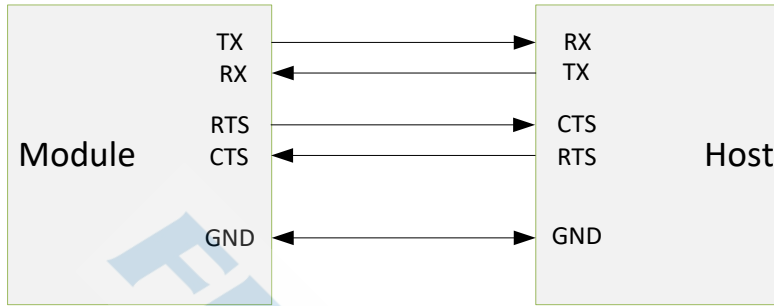

Figure 5-2: UART Connection

## 6. MSL&ESD

Table 6-1: MSL and ESD

Parameter	Value
MSL grade	MSL 3
ESD grade	Electrostatic discharge
ESD – Human Body Model (HBM) Rating JS - 001 - 2017	Pass ±3000 V, all pins
ESD – Charged Device Model (CDM) Rating JS - 002 - 2018	Pass ±800 V, all pins
Latch up Rating JESD78	± 800mA Class

## 7. RECOMMENDED TEMPERATURE REFLOW PROFILE

Prior to reflow, it is crucial to ensure that the modules are properly packaged to prevent moisture absorption. The new packages are equipped with desiccants to absorb moisture, and a humidity indicator card is included to indicate the moisture level maintained during storage and shipment. If the card indicates the need to bake the units, please refer to the instructions specified by IPC/JEDEC J-STD-033 and follow them accordingly. It is important to adhere to these instructions to prevent any potential moisture-related issues during the reflow process.

**Note:** The shipping tray should not be exposed to temperatures exceeding 65°C. If baking is necessary at higher temperatures indicated below, it is essential to remove the modules from the shipping tray. This precaution is important to avoid any potential damage or deformation to the tray caused by excessive heat.

Any module that exceeds its floor life but has not yet been manufactured should be repackaged by using new desiccants and humidity indicator cards. For devices with a Moisture Sensitivity Level (MSL) of 3, the floor life is 168 hours in an environment with 30°C/60%RH.

Floor life refers to the maximum allowable time a moisture-sensitive device can be exposed to ambient conditions without risking moisture absorption and potential damage during soldering.

*Notice (注意):*

*When using our modules, it is recommended to use a step steel mesh with a thickness of 0.16-0.20mm. However, the thickness can be adjusted according to the adaptability of your own product.*

**使用我司模块，须使用阶梯钢网，建议阶梯钢网厚度0.16-0.20mm，可根据自己产品适应性，进行相应调整。**

Table 7-1: Recommended baking times and temperatures

MSL	125°C Baking Temp.		90°C/≤ 5%RH Baking Temp.		40°C/ ≤ 5%RH Baking Temp.	
	Saturated @ 30°C/85%	Floor Life Limit + 72 hours @ 30°C/60%	Saturated @ 30°C/85%	Floor Life Limit + 72 hours @ 30°C/60%	Saturated @ 30°C/85%	Floor Life Limit + 72 hours @ 30°C/60%
3	9 hours	7 hours	33 hours	23 hours	13 days	9 days

Feasycom surface mount modules are designed to simplify manufacturing processes, such as reflow soldering on a PCB. However, Customers are responsible for selecting the appropriate solder paste and confirming that the oven temperatures during reflow meet with the specifications provided by the solder paste manufacturer. Notably, Feasycom surface mount modules adhere to the J-STD-020D1 standards for reflow temperatures.

The soldering profile may vary depending on different parameters, requiring a specific setup for each application. The data provided here is only intended as a general guideline for solder reflow and should be used as a reference.

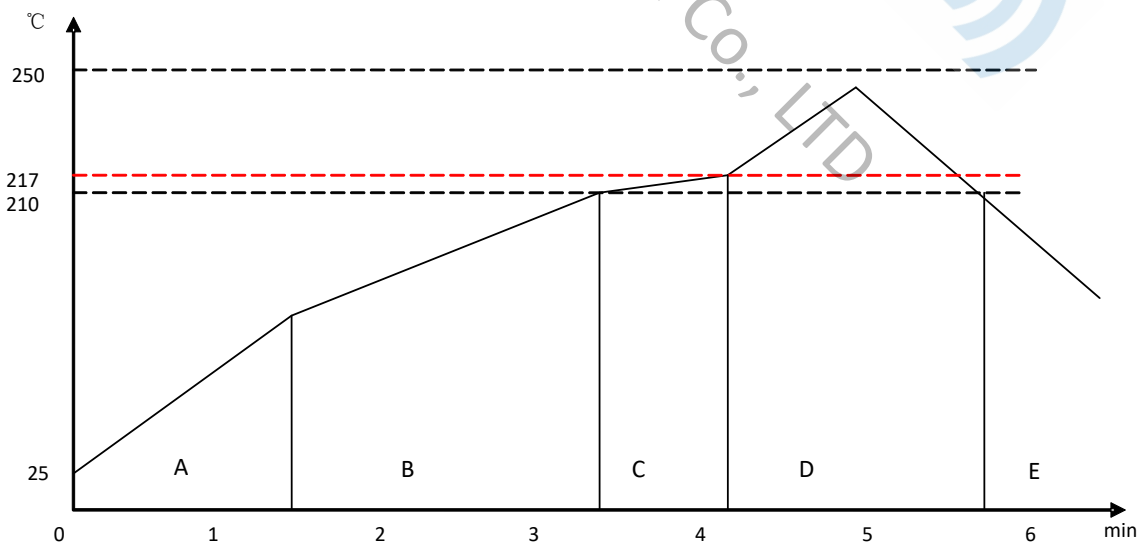

Figure 7-1: Typical Lead-free Re-flow

**Pre-heat zone (A)** — This zone gradually increases the temperature at a controlled rate, usually **ranging from 0.5 to 2 °C/s**. Its purpose is to preheat the PCB board and components to a temperature of 120-150 °C. This stage is necessary to ensure the even distribution of heat across the PCB board and to remove any remaining solvents completely, minimizing the risk of heat shock to the components.

**Equilibrium Zone 1 (B)** — In this stage, the flux undergoes softening and uniformly covers the solder particles, as well as spreading over the PCB board. This process helps prevent re-oxidation of the solder particles. Additionally, as the temperature rises and the flux liquefies, each activator and rosin component become activated. They work together to eliminate any oxide film formed on the surface of the solder particles and PCB board. **For this zone, it is recommended to maintain a temperature range of 150 to 210 °C for a duration of 60 to 120 seconds.**

**Equilibrium Zone 2 (C) (optional)** — To address the issue of upright components, it is recommended to maintain a temperature range of 210 to 217 °C for a duration of approximately 20 to 30 seconds. This will help ensure proper soldering and alignment of the components on the PCB board.

**Reflow Zone (D)** — The profile in the figure is designed for Sn/Ag3.0/Cu0.5. It can be a reference for other lead-free solder. The peak temperature should be high enough to achieve good wetting but not so high as to cause component discoloration or damage. Excessive soldering time can lead to intermetallic growth which can result in a brittle joint. The recommended peak temperature (Tp) is 230 ~ 250 °C. The soldering time should be 30 to 90 second when the temperature is above 217 °C.

**Cooling Zone (E)** — The cooling rate should be fast, to keep the solder grains small which will give a longer-lasting joint. **Typical cooling rate should be 4 °C.**

## 8. MECHANICAL DETAILS

### 8.1 Mechanical Details

- Dimension:
    - 17mm(L) x 17mm(W) x 2.4mm(H)(with shielding cover) Tolerance: ±0.2mm
    - 17mm(L) x 17mm(W) x 2.1mm(H)(without shielding cover) Tolerance: ±0.2mm
    - 17mm(L) x 17mm(W) x 1.7mm(H)(without shielding cover and IPEX) Tolerance: ±0.2mm
  - Module size: 17.00mm X 17.00mm Tolerance: ±0.2mm
  - Pad size: 1.5mmX0.75mm Tolerance: ±0.1mm
  - Pad pitch: 1.1mm Tolerance: ±0.1mm
- (Residual plate edge error: < 0.5mm)**

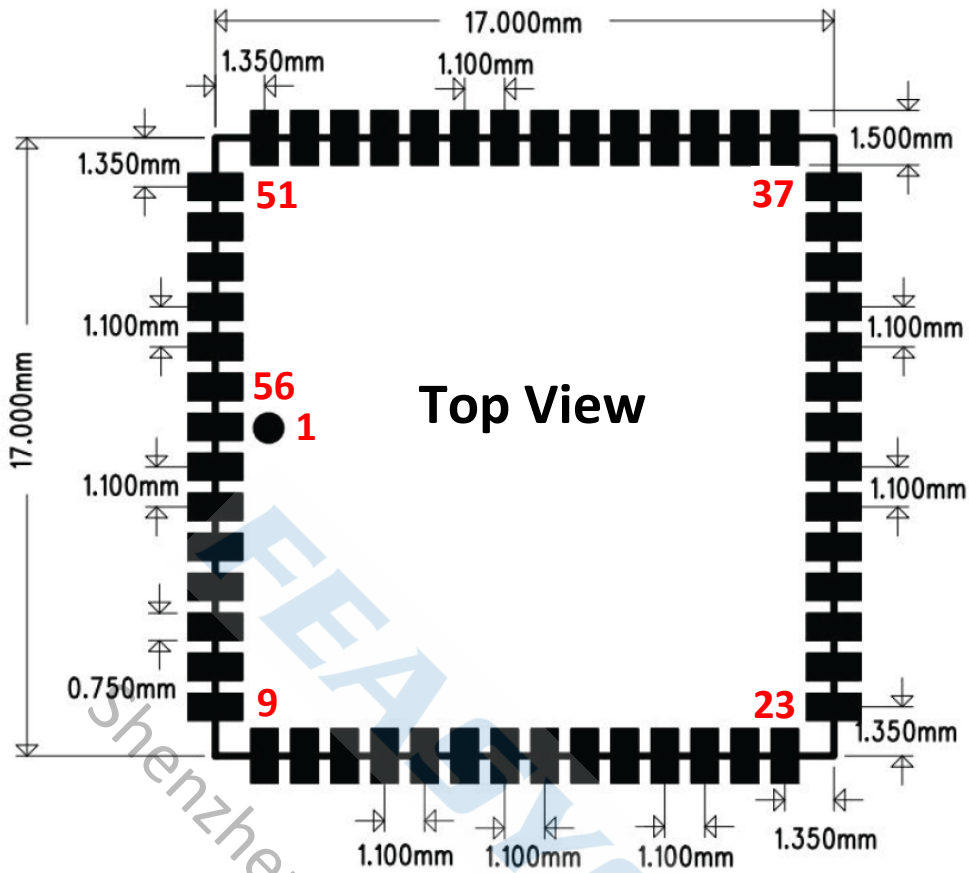

Figure 8-1: FSC-BW3583V footprint Layout Guide (Top View)

## 9. LAYOUT GUIDELINE

### 9.1 SDIO Lines Layout Guideline

The following SDIO line routing must obey the following rule to prevent overshoot/undershoot, as these lines drive 8mA.

SDIO\_DATA\_CMD

SDIO\_DATA\_CLK

SDIO\_DATA0

SDIO\_DATA1

SDIO\_DATA2

SDIO\_DATA3

The route length of these signals be less than 15 cm and the line impedance be less than 50Ω.

## 9.2 HCI Lines Layout Guideline

The following HCI line routing must obey the following rule to prevent overshoot/undershoot, as these lines drive 4 ~ 8mA.

UART1\_RX

UART1\_TX

UART1\_CTS

UART1\_RTS

The route length of these signals be less than 15 cm and the line impedance be less than 50Ω.

## 9.3 Power Trace Lines Layout Guideline

VDD\_3V3 Trace Width: 20mil

VDD\_IO Trace Width: 10mil

## 9.4 Ground Lines Layout Guideline

A Complete Ground in Ground Layer.

Add Ground Through Holes to FSC-BW3583V Module Ground Pads.

Decoupling Capacitors close to FSC-BW3583V Module Power and Ground Pads

## 9.5 Antenna Layout Guideline

The placement and PCB layout play a critical role in optimizing the performance of modules without on-board antenna designs. The trace connecting the antenna port of the module to an external antenna should have a characteristic impedance of 50Ω and should be kept as short as possible to prevent interference into the transceiver of the module. When positioning the external antenna and RF-IN port of the module, it is important to keep them away from any sources of noise and digital traces. To minimize return loss and achieve better impedance matching, a matching network may be required between the external antenna and RF-IN port.

To ensure proper RF performance, it is recommended to clearly separate the RF critical circuits of the module from any digital circuits on the system board. The RF circuits within the module are located near the antenna port. Therefore, the module should be placed in such a way that the module's digital part faces the digital section of the system PCB.

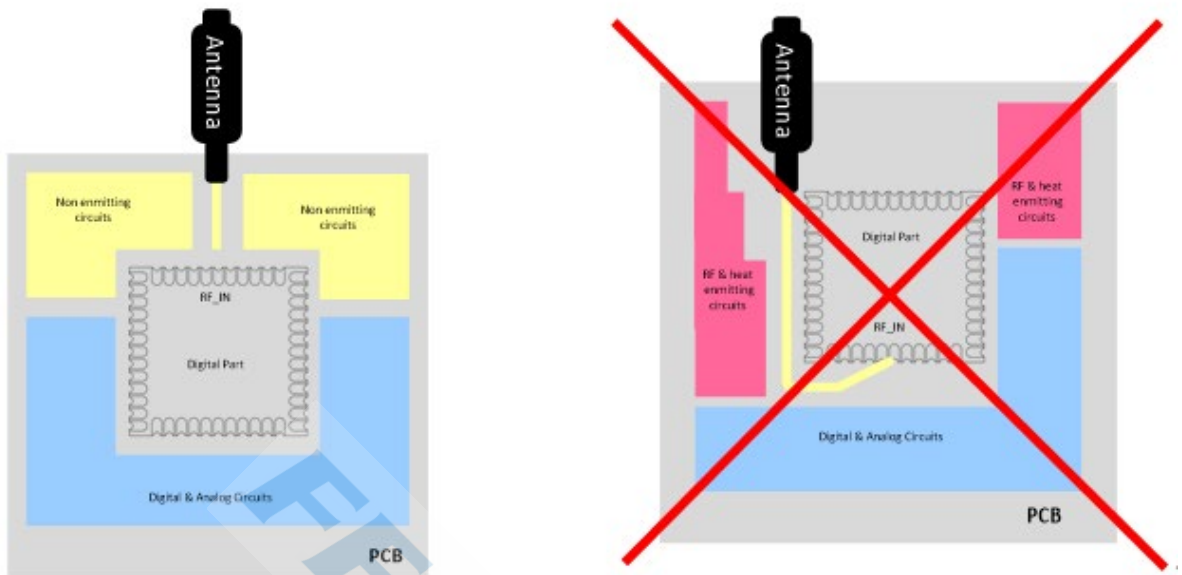

Figure9-5-1: Placement the Module on a System Board

**9.6 Antenna Connection and Grounding Plane Design**

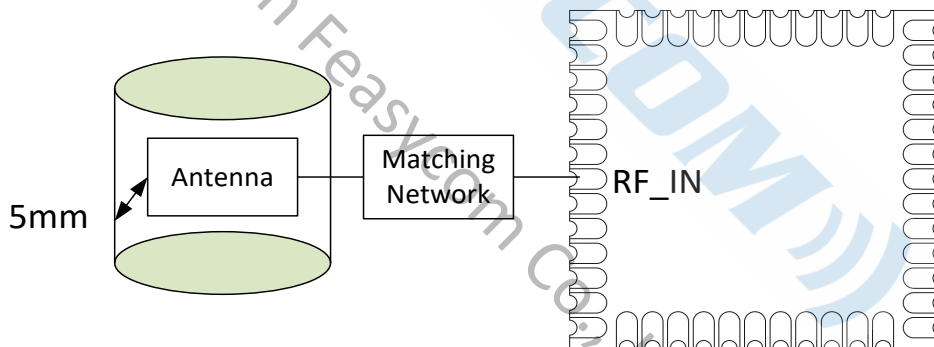

Figure 9-6-1: Leave 5mm Clearance Space from the Antenna

General design recommendations are as follows:

- The length of the trace or connection line should be kept as short as possible.
- Distance between connection and ground area on the top layer should be at least as large as the dielectric thickness.
- Routing the RF close to digital sections of the system board should be avoided.
- To reduce signal reflections, sharp angles in the routing of the micro strip line should be avoided. Chamfers or fillets are preferred for rectangular routing; 45-degree routing is preferred over Manhattan style 90-degree routing.

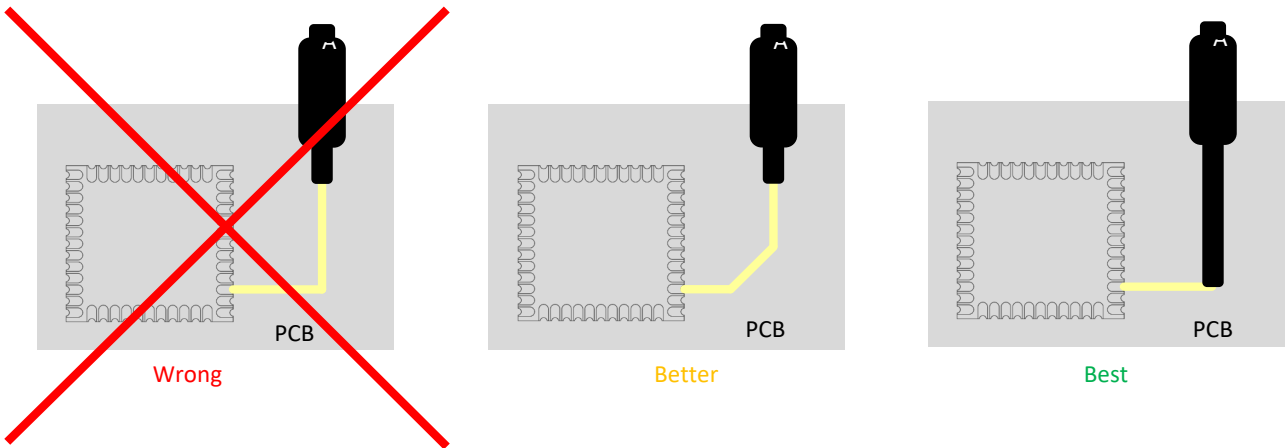

Figure9-6-2 : Recommended Trace Connects Antenna and the Module

- Routing of the RF-connection underneath the module should be avoided. The distance of the micro strip line to the ground plane on the bottom side of the receiver is very small and has huge tolerances. Therefore, the impedance of this part of the trace cannot be controlled.
- Use as many vias as possible to connect the ground planes.

## 10. PRODUCT PACKAGING INFORMATION

### 10.1 Default Packing

- a, Tray vacuum
- b, Tray Dimension: 230mm \* 125mm \* 8mm



Figure 10-1-1: Tray vacuum

## 10.2 Packing box (Optional)

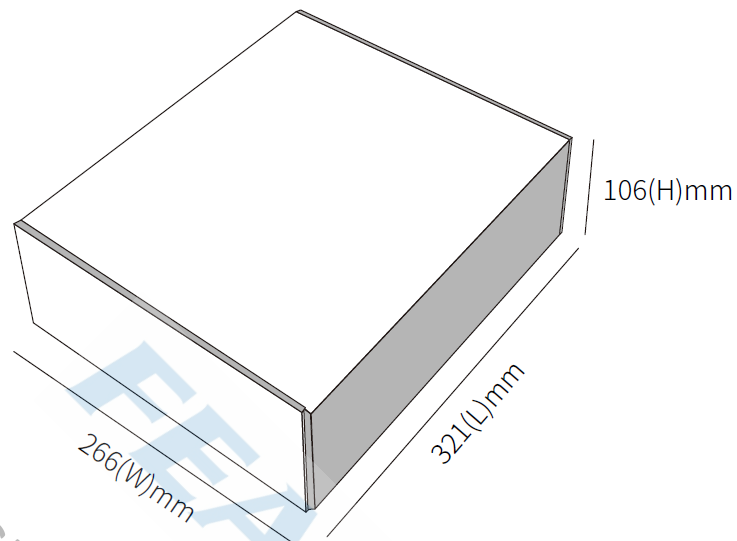

Figure 10-2-1: Packing box(Optional)

---

*\* If any packaging other than the package mentioned above is required, please confirm the packaging size again.*

*\* Packing: 1000pcs per carton (Minimum packing quantity).*

*\* The outer packing size provided above is for reference purposes only. For the actual dimensions of the product's packaging, please refer to the packaging of the actual goods.*

---

# 11.APPLICATION SCHEMATIC

Dual-band antenna0/1:  
2402MHz~2484MHz /4900MHZ~5925MHz  
Reserved  $\pi$ -type matching circuit RF  
path controlled by 50 ohm impedance

ANT1

It is recommended to use the IPEX generation antenna holder and use the FPC dual frequency antenna that has been verified by Feasycom

ANT0

